

Trimer-tetramer interwoven states in the scaling limit

Lauro Tomio

Centro de Ciências Naturais e Humanas, Universidade Federal do ABC, Santo André, Brasil
and
Instituto de Física Teórica, UNESP, São Paulo, Brasil
tomio@ift.unesp.br

Collaboration with:

M. R. Hadizadeh^{1,2}, M. T. Yamashita¹, T. Frederico³ and A. Delfino⁴

¹Instituto de Física Teórica, UNESP, São Paulo, Brasil

²Ohio University, Athens, USA

³Instituto Tecnológico de Aeronáutica, São José dos Campos, Brasil

⁴Universidade Federal Fluminense, Niterói, Brasil

1 Introduction

- The 3-body Thomas-Efimov effect and few-body scales
- The Problem
- Our Aim

2 Three-body Scaling

- Thomas-Efimov effect
- 3-Boson Scaling / Limit cycle

3 Four-body Scaling

- Formalism: Faddeev-Yakubovsky equations
- 4B states pumping out from the atom-trimer threshold

4 Three- and Four-body interwoven cycles

- 4B Scaling Plot
- Three- and Four-body Interwoven Cycles

5 Summary

Outline

- 1 Introduction**
 - The 3-body Thomas-Efimov effect and few-body scales
 - The Problem
 - Our Aim
- 2 Three-body Scaling**
 - Thomas-Efimov effect
 - 3-Boson Scaling / Limit cycle
- 3 Four-body Scaling**
 - Formalism: Faddeev-Yakubovsky equations
 - 4B states pumping out from the atom-trimer threshold
- 4 Three- and Four-body interwoven cycles**
 - 4B Scaling Plot
 - Three- and Four-body Interwoven Cycles
- 5 Summary**

Abstract

From recent studies on four-body scaling and the corresponding relation with Efimov trimers [Hadizadeh et al. Phys. Rev. A 87, 013620 (2013); Phys. Rev. Lett. 107, 135304 (2011)] (which we briefly revise in this presentation) we report some new results.

The scale dependence of tetramer bound-state energies is explored at the unitary limit, considering the number of tetramer energy levels between the ground and the excited trimers.

The corresponding ratio between three- and four-body scales is verified, in order to obtain more than two tetramers between two Efimov trimers.

The Thomas-Efimov effect

- **Unitary limit** ($a \rightarrow \pm\infty$): $\frac{E_3^n}{E_3^{n+1}} \approx (22.7)^2 \rightarrow$ discrete scaling
- **For finite a :** the discrete scaling is exact when the range $\rightarrow 0$
- **Thomas-Efimov effect:** For $a \gg$ interaction range with large three-body states \implies use of **zero-range interaction!**

Scaling functions - three-boson system

- **Universality:** large states predominantly on the classical forbidden region, with solution given by a free Schrödinger equation (Skorniakov-Ter-Martirosian equation)
- Renormalization of contact interaction are set by a dimer and a trimer parameters
- **Scaling functions:** the correlation between two three-body observables (limit cycle for $n \rightarrow \infty$!)
- **Applications:** Universal plots in three-body systems

What about a **Four-Body** system?

Four-body scale and scaling functions

- The physics of tetramers close to the unitary limit (scattering length, $a = \pm\infty$) with short-range interactions, requires a four-body scale[†] [[Yamashita et al EPL75 \(2006\)](#)].
- Scaling of the binding energies of two successive tetramers between two Efimov trimers leads to a **four-body limit cycle** [[Hadizadeh et al PRL107\(2011\)](#)].
- Scaling of the positions of successive four-atom resonant recombination peaks for $a < 0$. Experimental data exists!

[†] For other related works, see:

L. Platter et al., *PRA***70** (2004); H.-W. Hammer and L. Platter, *EPJA***32** (2007).

J. von Stecher, et al., *Nature Physics* **5** (2009); J. von Stecher, *JPB***43** (2010) & *PRL***107** (2011)

A. Deltuva, *PRA***82** (2010), *PRA***85** (2012)

Problem: Position of four-atom resonant recombination

- Positions of four-atom recombination peaks ($a < 0$) where two successive tetramers become unbound (blue-solid line). Cesium atoms wide Feshbach resonances.
- (First point from the left corresponds to $B_4 \simeq 64 B_3$ at the unitary limit.)

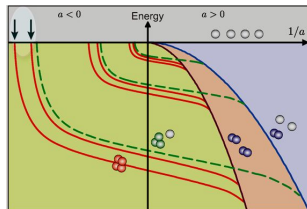
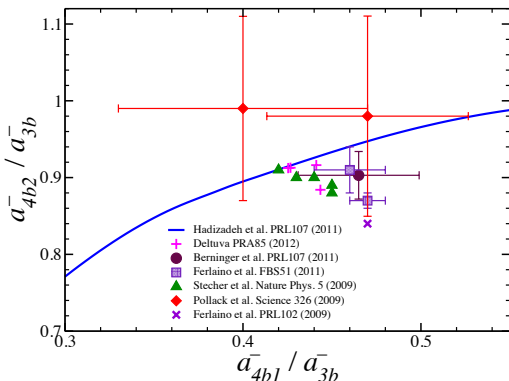

Our Aim

- Study the correlation between 4-body states attached to successive 3-body Efimov states (the trimer-tetramer interwoven states)
- Introduce range corrections to the tetramer scaling functions calculated with the zero-range model;

Outline

- 1 **Introduction**
 - The 3-body Thomas-Efimov effect and few-body scales
 - The Problem
 - Our Aim
- 2 **Three-body Scaling**
 - Thomas-Efimov effect
 - 3-Boson Scaling / Limit cycle
- 3 **Four-body Scaling**
 - Formalism: Faddeev-Yakubovsky equations
 - 4B states pumping out from the atom-trimer threshold
- 4 **Three- and Four-body interwoven cycles**
 - 4B Scaling Plot
 - Three- and Four-body Interwoven Cycles
- 5 **Summary**

Zero-range 3-boson equation: Thomas-Efimov effect

Skorniakov and Ter-Martirosian equations (1956)

$$\chi(\vec{y}) = \frac{-\pi^{-2}}{\pm\sqrt{\epsilon_2} - \sqrt{\epsilon_3 + \frac{3}{4}y^2}} \int d^3x \left(\frac{1}{\epsilon_3 + y^2 + x^2 + \vec{y} \cdot \vec{x}} - \frac{1}{1 + y^2 + x^2 + \vec{y} \cdot \vec{x}} \right) \chi(\vec{x})$$

$$\epsilon_3 = E_3 + \mu_{(3)}^2 \quad \epsilon_2 = E_2 + \mu_{(3)}^2 \quad \mu_{(3)}^2 = 1$$

Adhikari,TF,Goldman, PRL74 (1995) 487

Thomas collapse: $\mu_{(3)}^2 \rightarrow \infty$

$$\epsilon_2 = E_2 + \mu_{(3)}^2$$

Efimov effect: $E_2 \rightarrow 0$

$$\epsilon_3^{(N)} \equiv \epsilon_3^{(N)} (\pm \sqrt{\epsilon_2})$$

Scaling limit & limit cycle

$$\epsilon_3^{(N)} \equiv \epsilon_3^{(N)} (\pm \sqrt{\epsilon_2})$$

$$\xi \equiv \pm \sqrt{\epsilon_2} = \pm (E_2 \epsilon_3^{(N)} / E_3^{(N)})^{1/2}$$

$$\frac{E_3^{(N+1)}}{E_3^{(N)}} = \lim_{N \rightarrow \infty} \frac{\epsilon_3^{(N+1)}(\xi)}{\epsilon_3^{(N)}} = \mathcal{F} \left(\pm \sqrt{\frac{E_2}{E_3^{(N)}}} \right) \quad \mathcal{F}(0) = 1/515$$

Scaling function

Efimov 1970

Scaling limit:

Frederico et al PRA60 (1999)R9

Yamashita et al PRA66(2003)052702

Limit cycle:

Mohr et al Ann.Phys. 321 (2006)225

Bedaque et al. PRL82, 463 (1999)

Outline

- 1 Introduction**
 - The 3-body Thomas-Efimov effect and few-body scales
 - The Problem
 - Our Aim
- 2 Three-body Scaling**
 - Thomas-Efimov effect
 - 3-Boson Scaling / Limit cycle
- 3 Four-body Scaling**
 - Formalism: Faddeev-Yakubovsky equations
 - 4B states pumping out from the atom-trimer threshold
- 4 Three- and Four-body interwoven cycles**
 - 4B Scaling Plot
 - Three- and Four-body Interwoven Cycles
- 5 Summary**

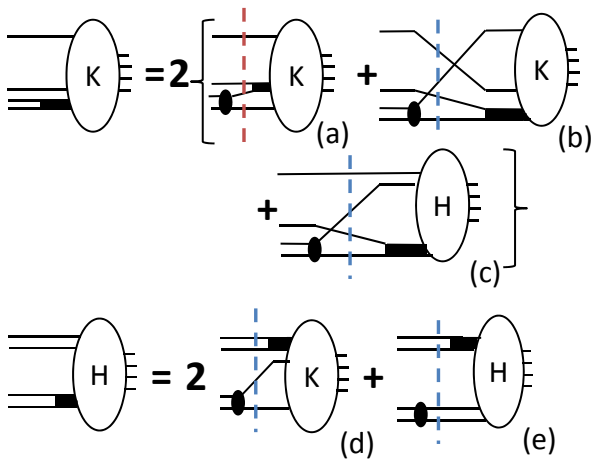

Subtracted Green's Functions: $G_0^{(N)} = \frac{1}{E-H_0} - \frac{1}{-\mu_N^2-H_0}$

with μ_3 (RED): 3B scale & μ_4 (BLUE): 4B scale

Subtracted STM equations

$$|\mathcal{K}_{ij,k}\rangle = 2\tau(\epsilon_{ij,k}) \mathcal{G}_{ij,ik}^{(3)} |\mathcal{K}_{ik,j}\rangle, \quad \mathcal{G}_{ij,ik}^{(3)} = \langle \chi_{ij} | \left(\frac{1}{E - H_0} - \frac{1}{-\mu_3^2 - H_0} \right) | \chi_{ik} \rangle$$

Subtracted FY equations [Yamashita et al EPL75(2006)]

$$|\mathcal{K}_{ij,k}^l\rangle = 2\tau(\epsilon_{ij,k}^l) \left[\mathcal{G}_{ij,ik}^{(3)} |\mathcal{K}_{ik,j}^l\rangle + \mathcal{G}_{ij,ik}^{(4)} \left(|\mathcal{K}_{ik,l}^j\rangle + |\mathcal{H}_{ik,jl}\rangle \right) \right],$$

$$|\mathcal{H}_{ij,kl}\rangle = \tau(\epsilon_{ij,kl}) \mathcal{G}_{ij,kl}^{(4)} \left[2 |\mathcal{K}_{kl,i}^j\rangle + |\mathcal{H}_{kl,ij}\rangle \right],$$

$$\mathcal{G}_{ij,ik}^{(4)} = \langle \chi_{ij} | \left(\frac{1}{E - H_0} - \frac{1}{-\mu_4^2 - H_0} \right) | \chi_{ik} \rangle$$

2-body subsystems (ij) energies: $\epsilon_{ij,k}^l$ and $\epsilon_{ij,kl}$ for 3+1 and 2+2 partitions.

s-wave tetramers emerging from the atom-trimer continuum @ unitarity

- μ_4/μ_3 increasing...

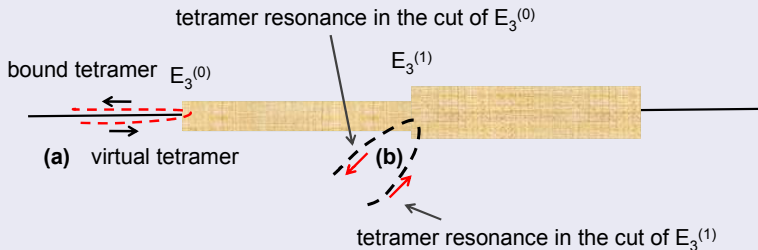

Outline

- 1 Introduction**
 - The 3-body Thomas-Efimov effect and few-body scales
 - The Problem
 - Our Aim
- 2 Three-body Scaling**
 - Thomas-Efimov effect
 - 3-Boson Scaling / Limit cycle
- 3 Four-body Scaling**
 - Formalism: Faddeev-Yakubovsky equations
 - 4B states pumping out from the atom-trimer threshold
- 4 Three- and Four-body interwoven cycles**
 - 4B Scaling Plot
 - Three- and Four-body Interwoven Cycles
- 5 Summary**

4B Limit Cycle: Scaling Plot

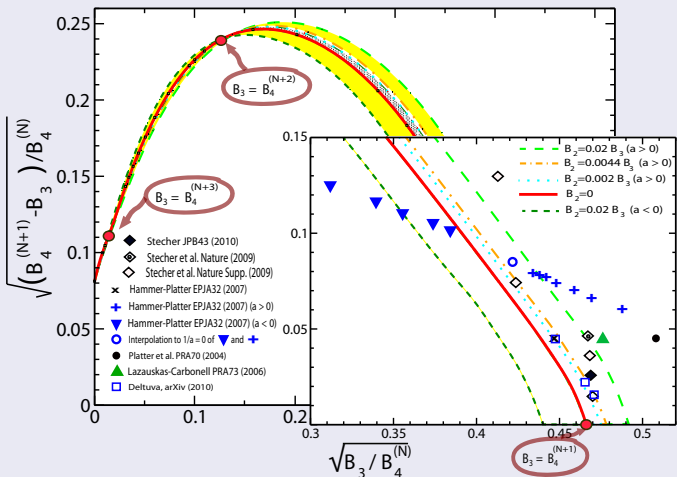

Three-body scaling

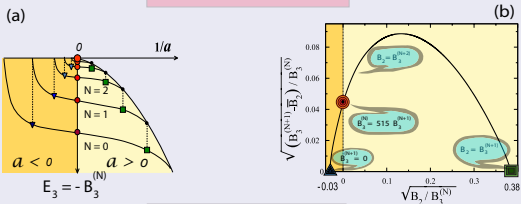

Four-body scaling

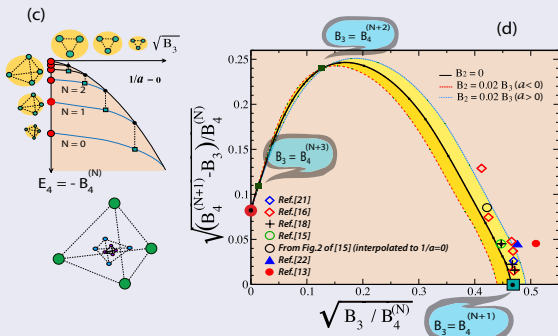

3B and 4B Interwoven Cycles

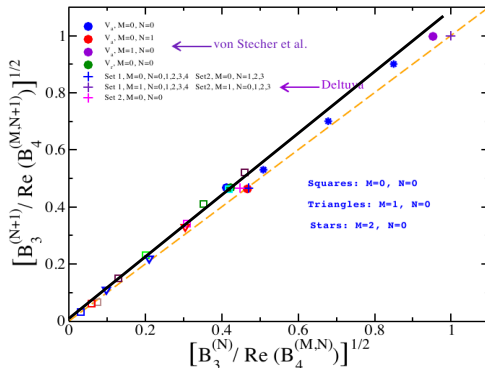

The fate of tetramers: cross the trimers thresholds...

3B and 4B Interwoven Cycles

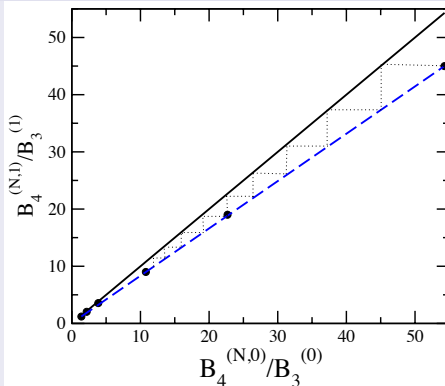

The fate of tetramers: cross the trimers thresholds...

3B and 4B Interwoven Cycles

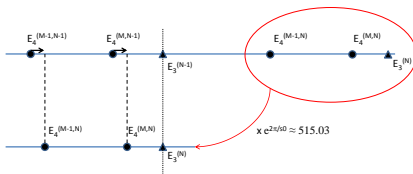

The fate of tetramers: cross the trimers thresholds...

Outline

- 1 Introduction**
 - The 3-body Thomas-Efimov effect and few-body scales
 - The Problem
 - Our Aim
- 2 Three-body Scaling**
 - Thomas-Efimov effect
 - 3-Boson Scaling / Limit cycle
- 3 Four-body Scaling**
 - Formalism: Faddeev-Yakubovsky equations
 - 4B states pumping out from the atom-trimer threshold
- 4 Three- and Four-body interwoven cycles**
 - 4B Scaling Plot
 - Three- and Four-body Interwoven Cycles
- 5 Summary**

Summary

- Introduction: 3-body Efimov scaling limit
- Four-body formalism and the few-body scales
- Tetramers-trimers interwoven limit cycles - effect of four-body scale
- Numerical results are preliminary, with improved accuracy.

Thank you :)