

Phenomenological studies of the low energy dynamics in the ppK^+K^- system



Michał Silarski
Jagiellonian University



- ❖ **Motivation**
- ❖ **Proton-proton collisions at K^+K^- threshold: COSY**
- ❖ **Dynamics of the ppK^+K^- system at threshold**
- ❖ **Conclusions & outlook**

The 22nd European Conference on Few-Body Problems in Physics
Kraków, Poland, 9 - 13 September 2013

Motivation

- ❖ a_0 and f_0 mesons as a K^+K^- molecules
- ❖ Physics of neutron stars:
kaon condensates
- ❖ Structure of the $\Lambda(1405)$ hyperon

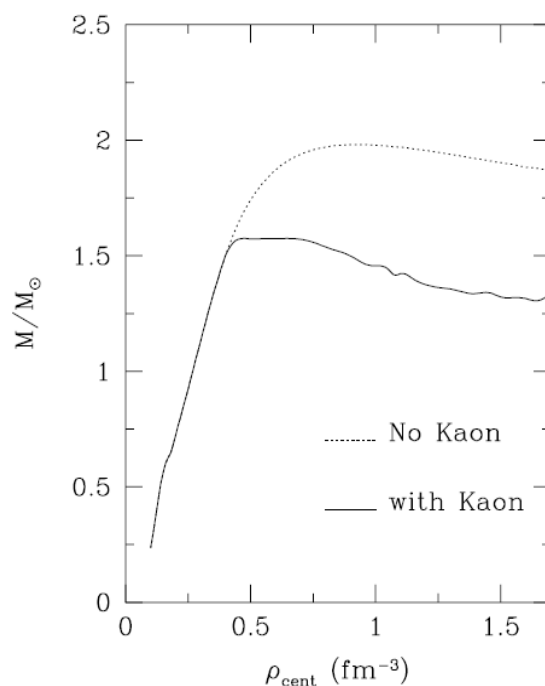
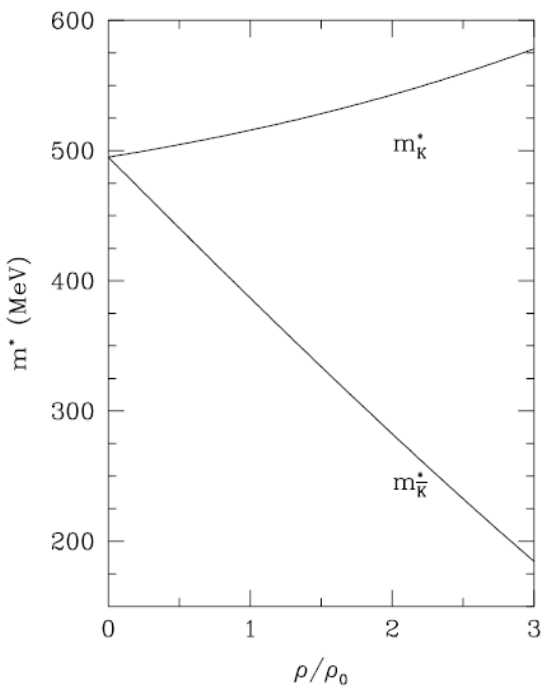

Pseudoscalar mesons

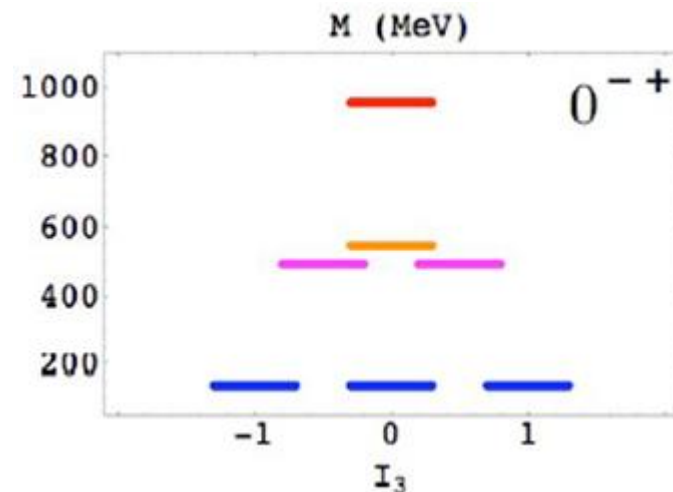

Scalar multiplet:
 $\sigma(500)$, $\kappa(700)$, $f_0(980)$, $a_0(980)$

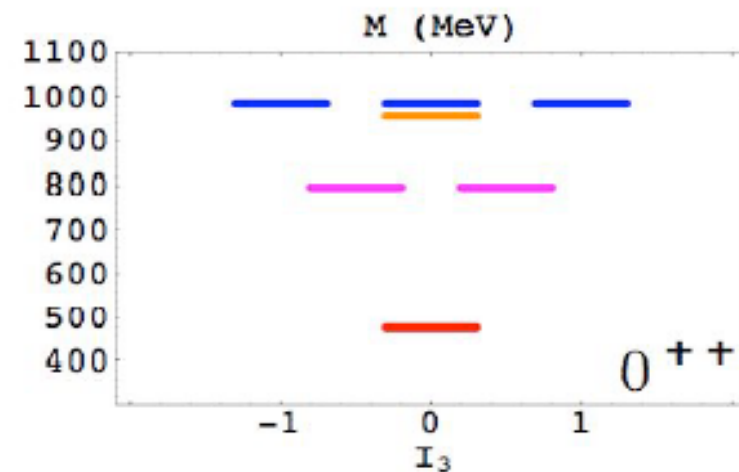

COoler SYNchrotron COSY

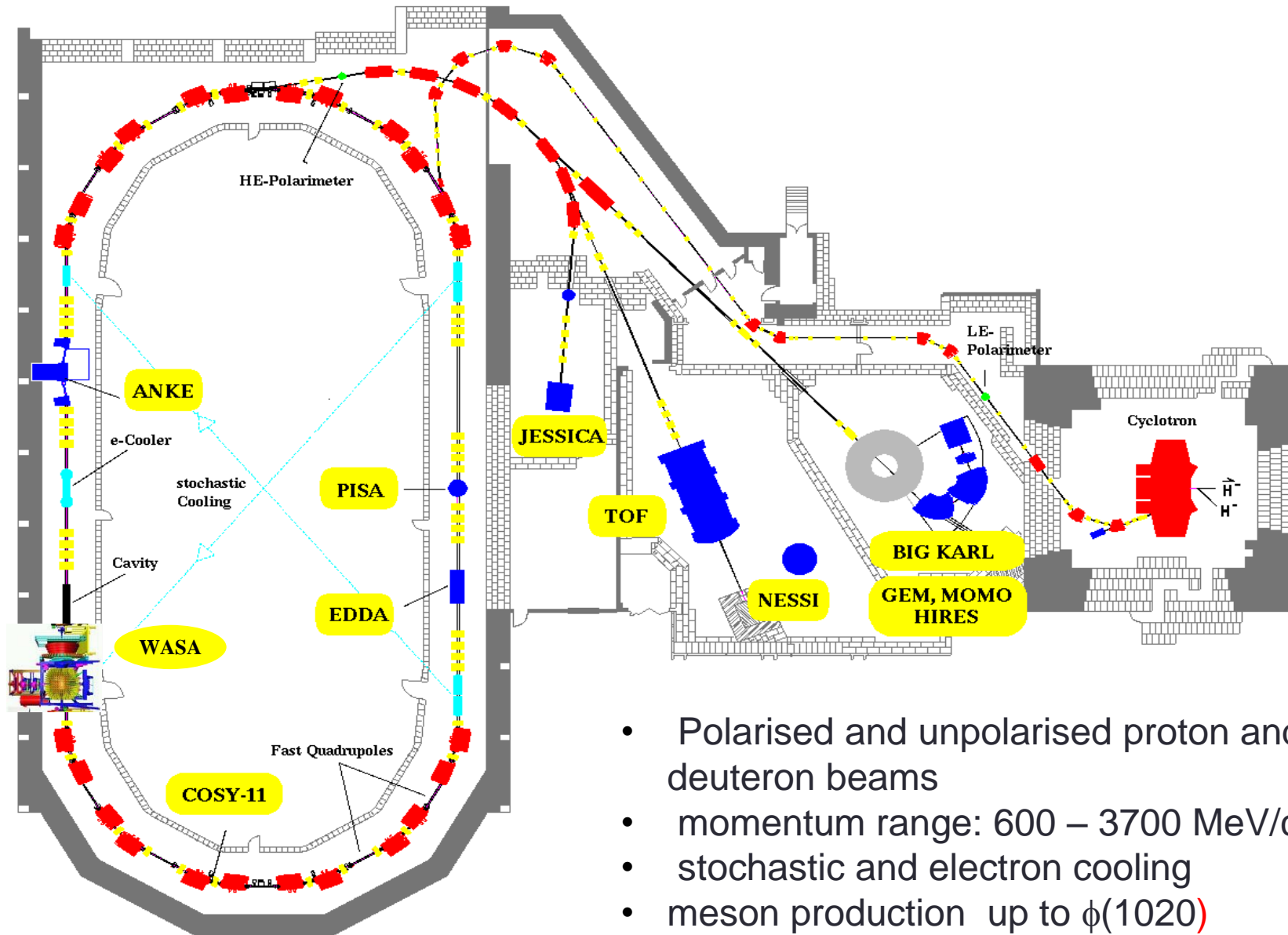



COSY-11

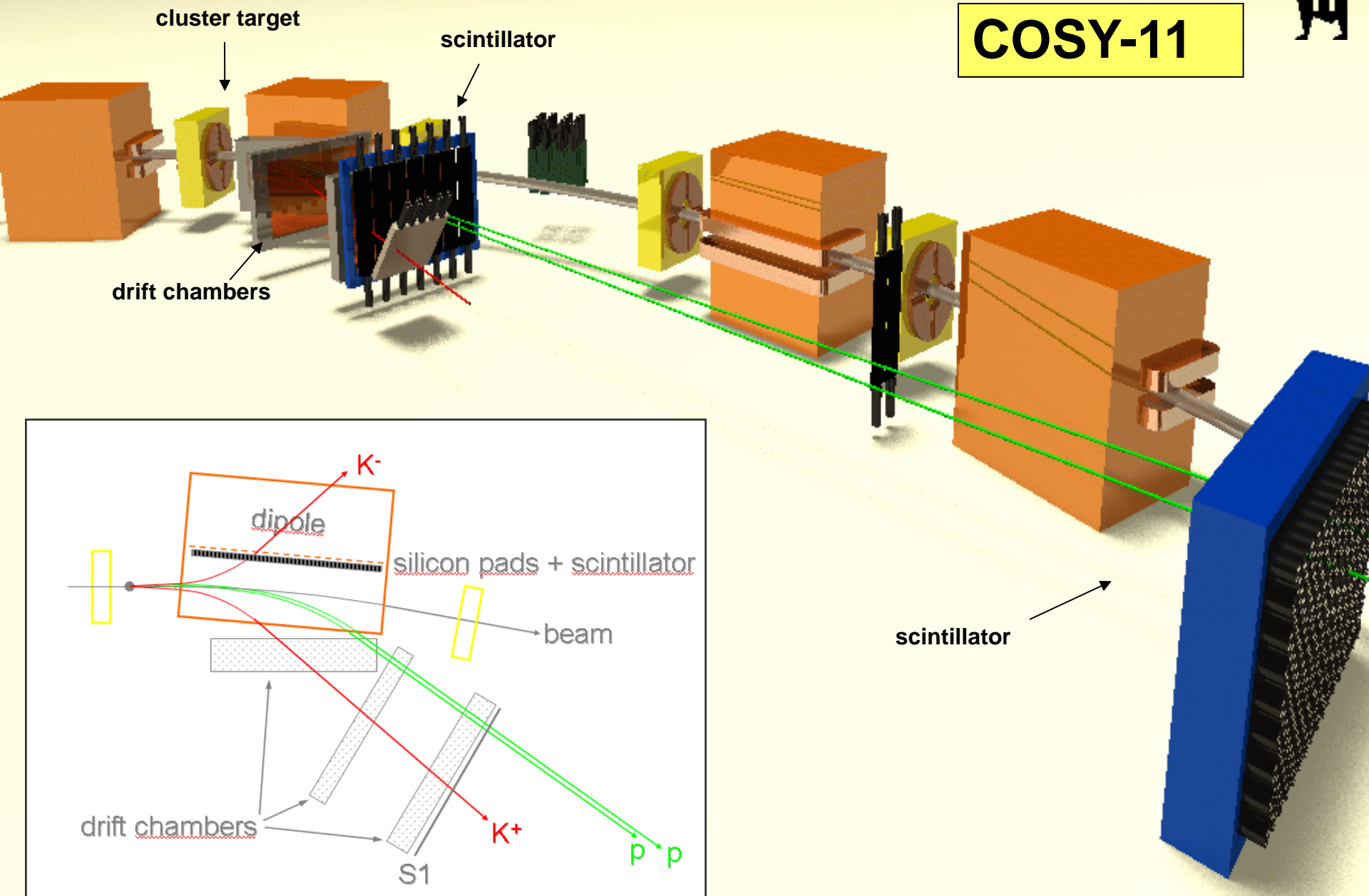



COSY-11

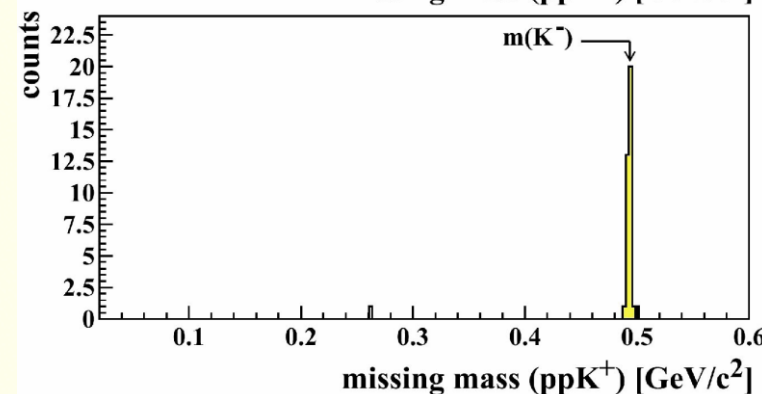
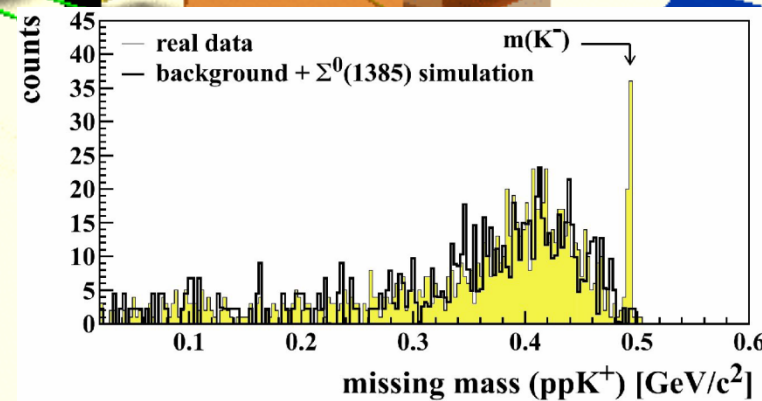
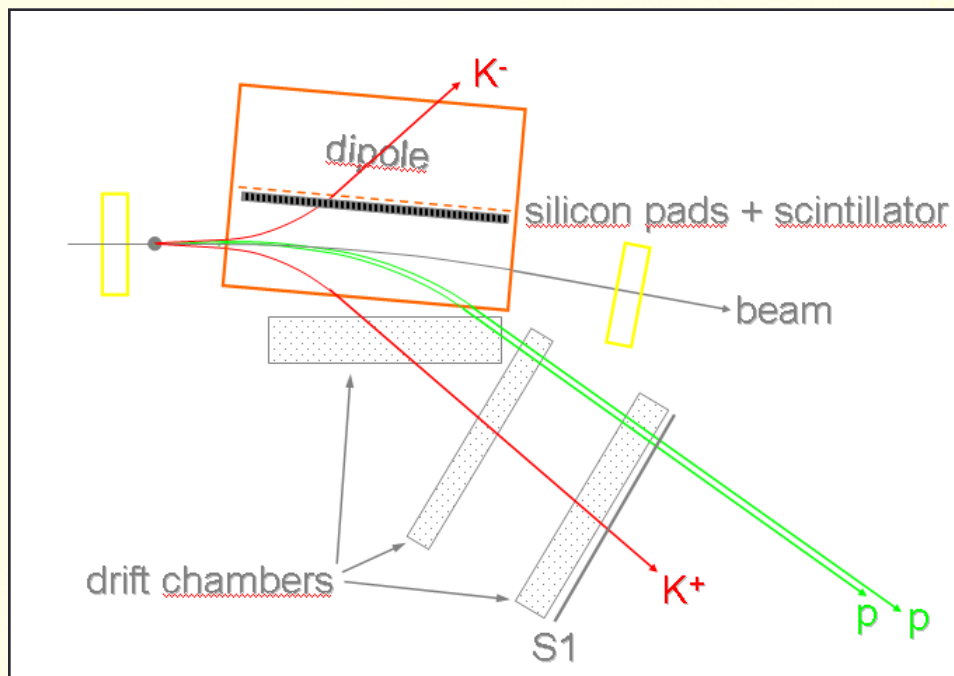
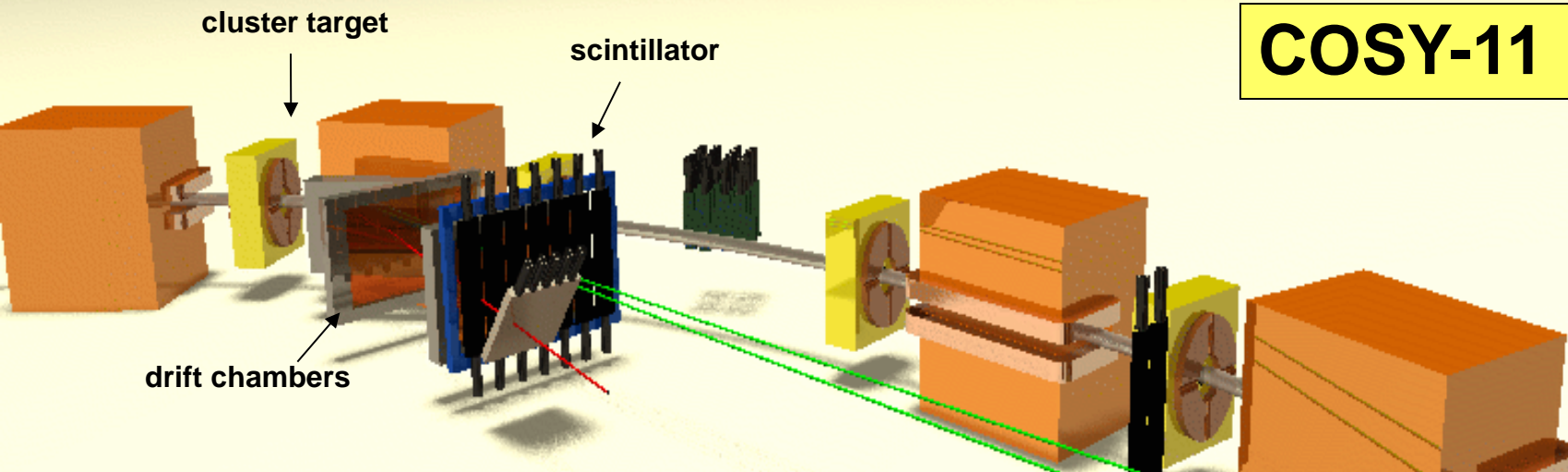

ANKE

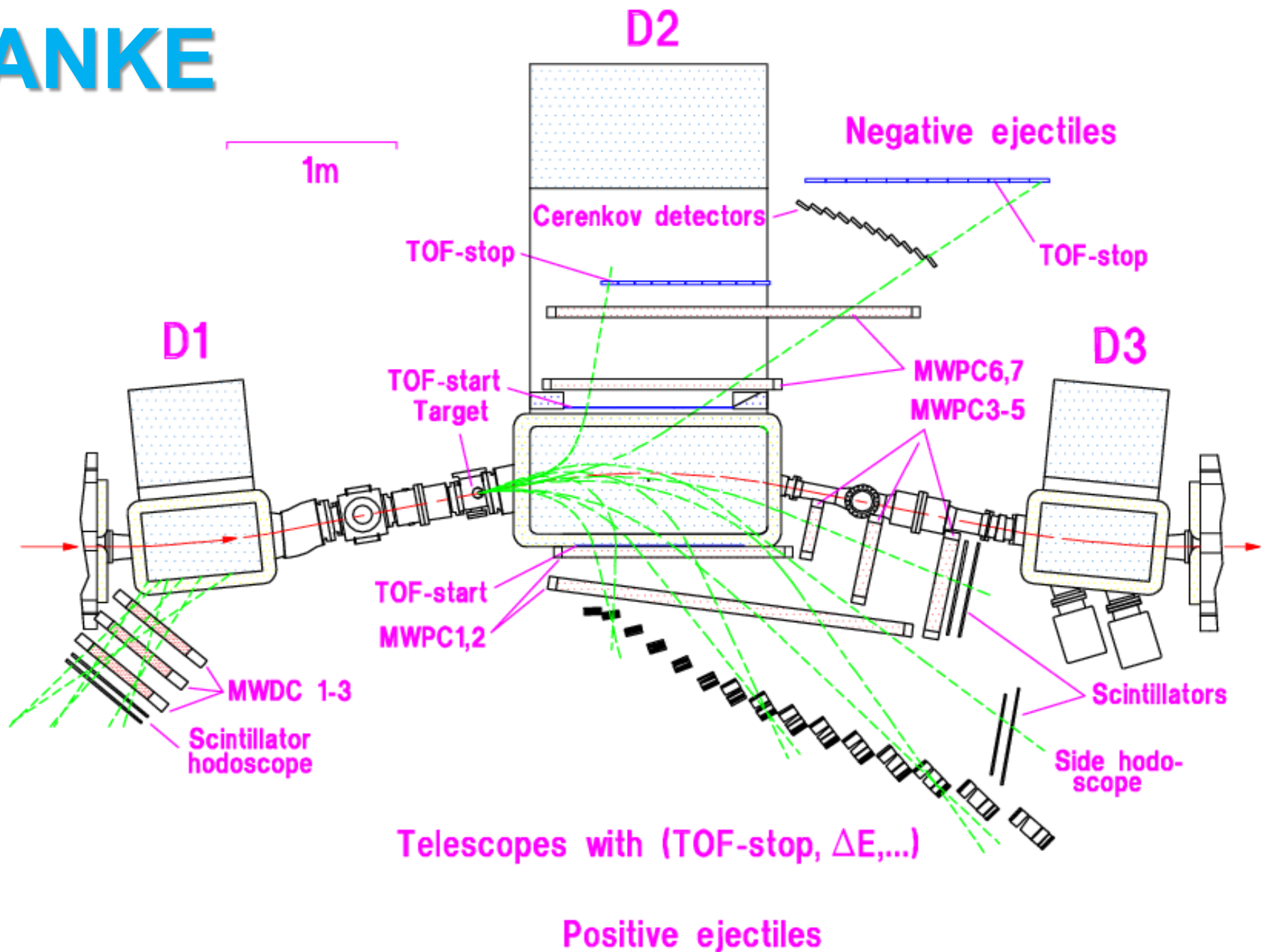

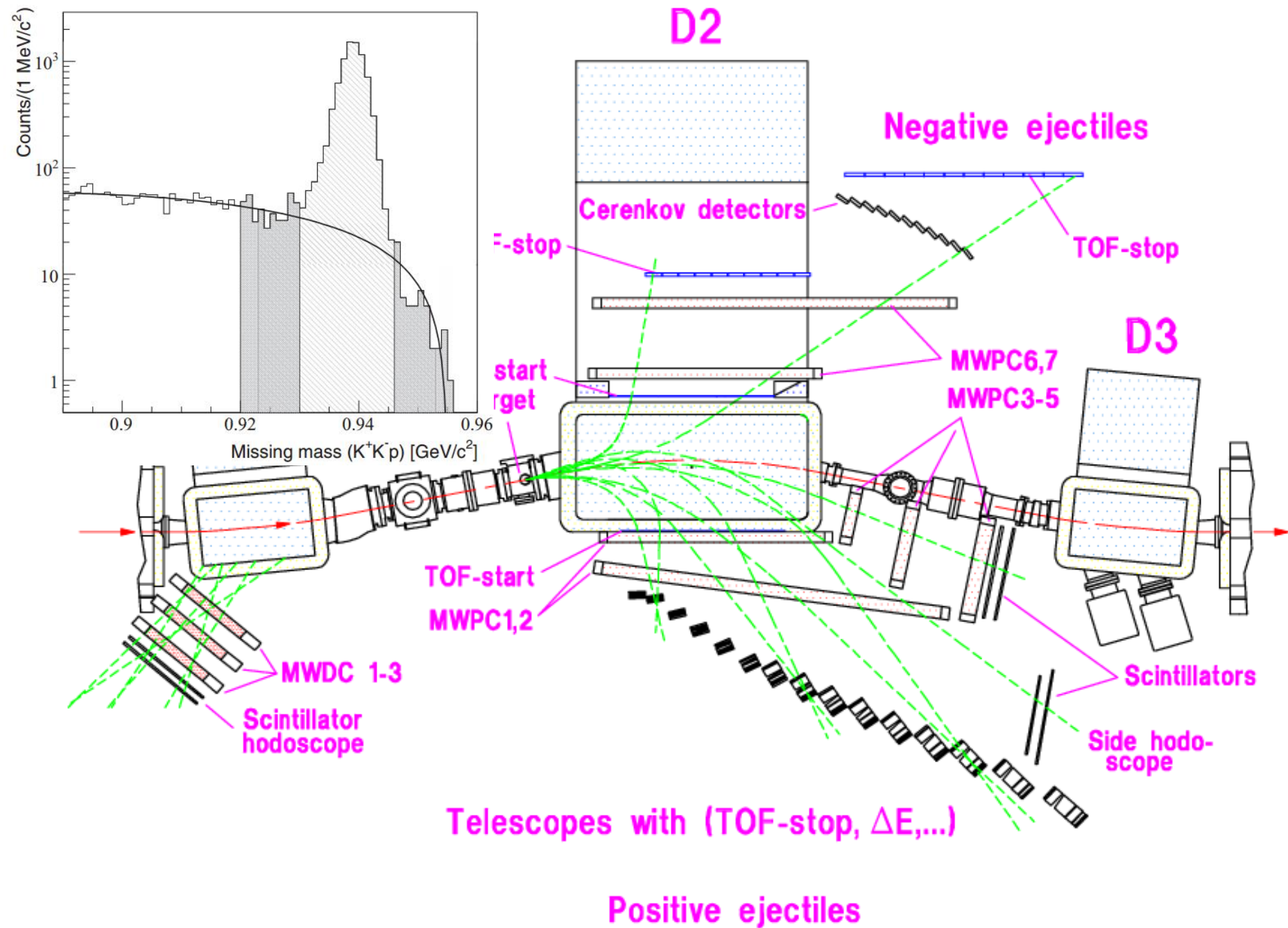

The $pp \rightarrow ppK^+K^-$ excitation function

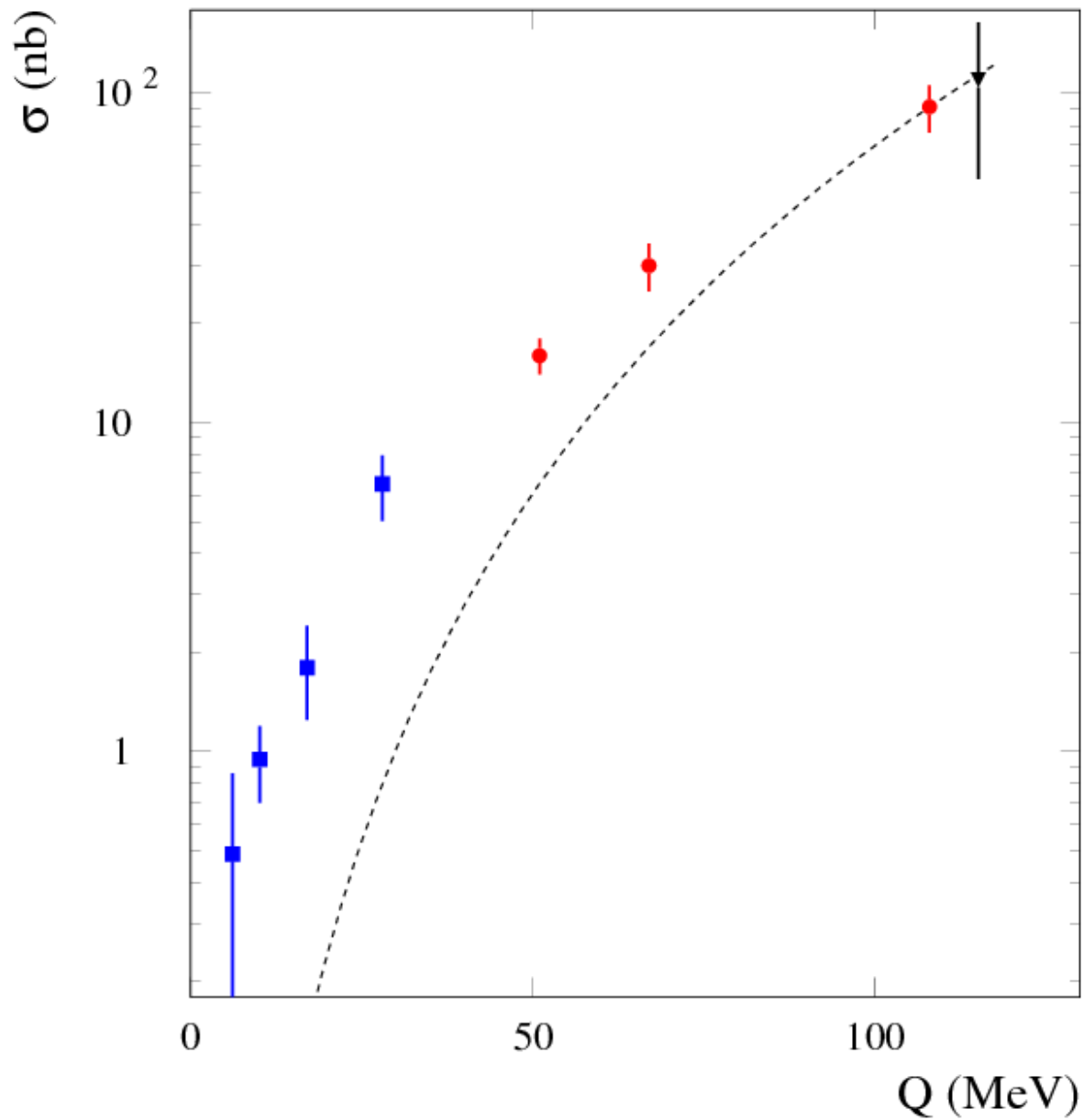

**DISTO: F. Balestra et al.,
Phys. Rev. C 63, 024004 (2001)**

**ANKE: Y. Maeda et al.,
Phys., Rev. C 77, 01524 (2008)**

**ANKE: Q. J. Ye et al.,
Phys. Rev. C 85, 035211 (2012)**

**COSY-11: C. Quentmeier et al.,
Phys. Lett. B 515 (2001) 276-282**

**COSY-11: P. Winter et al.,
Phys. Lett. B 635 (2006) 23-29**

COSY-11: M. Wolke, PhD thesis

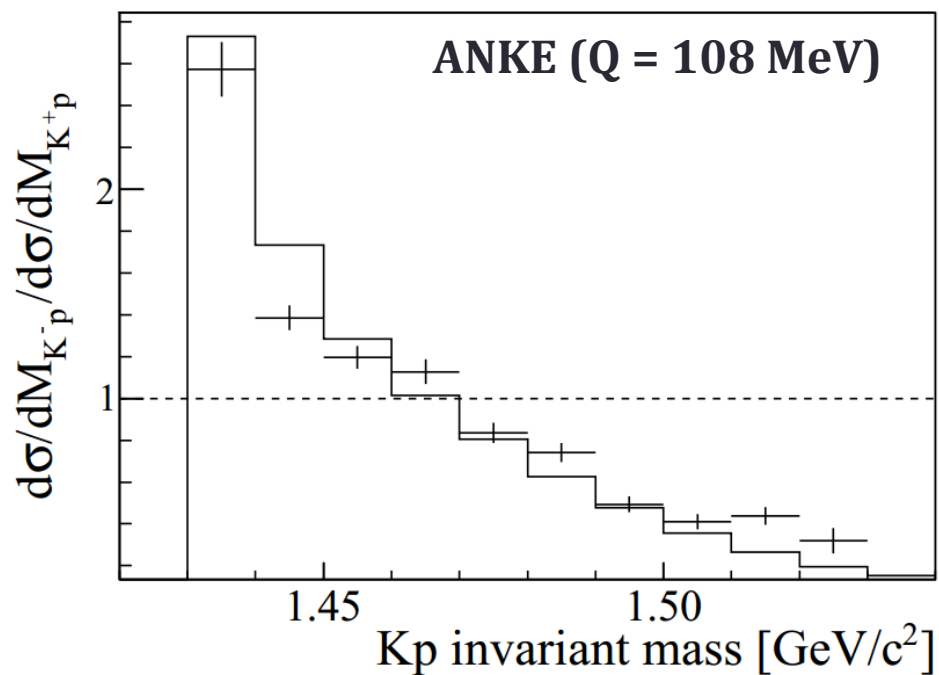
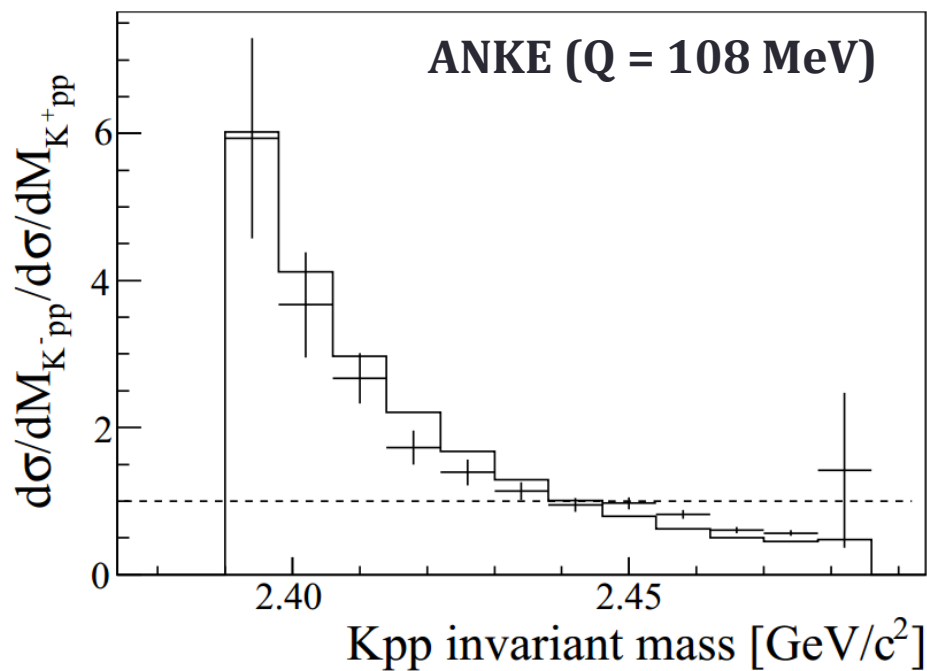
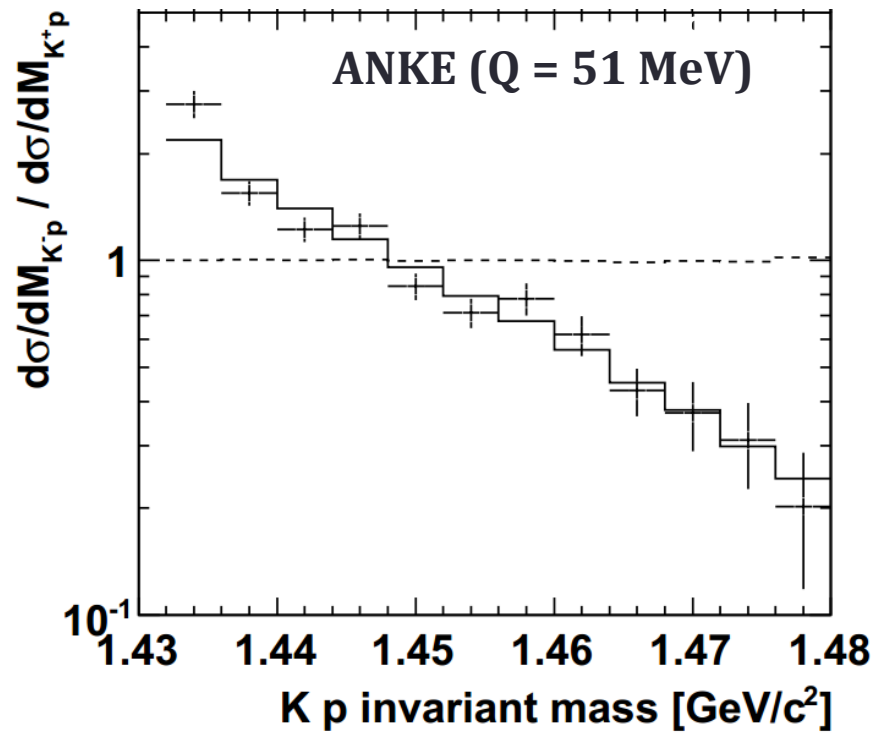
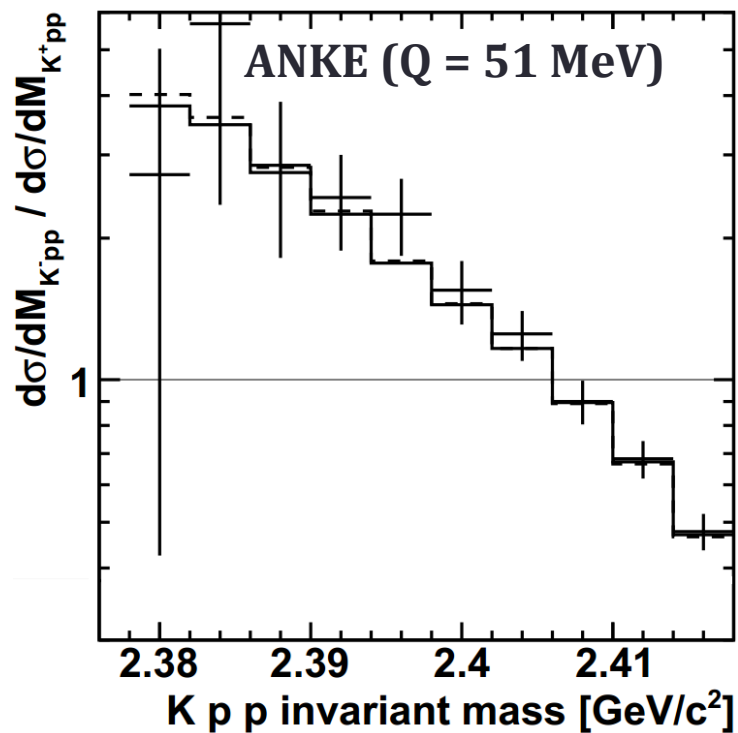

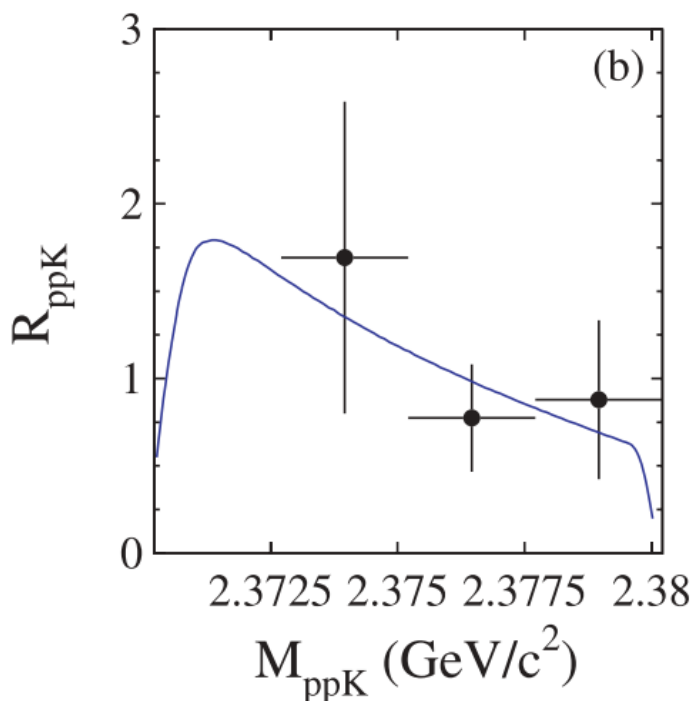
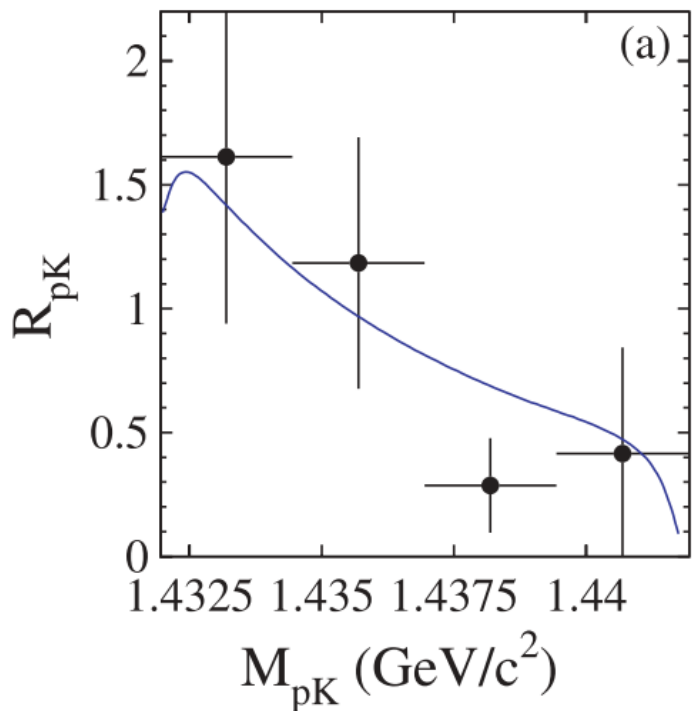

COSY-11
(Q = 10 MeV)

$$R_{pK} = \frac{d\sigma/dM_{pK^-}}{d\sigma/dM_{pK^+}}$$

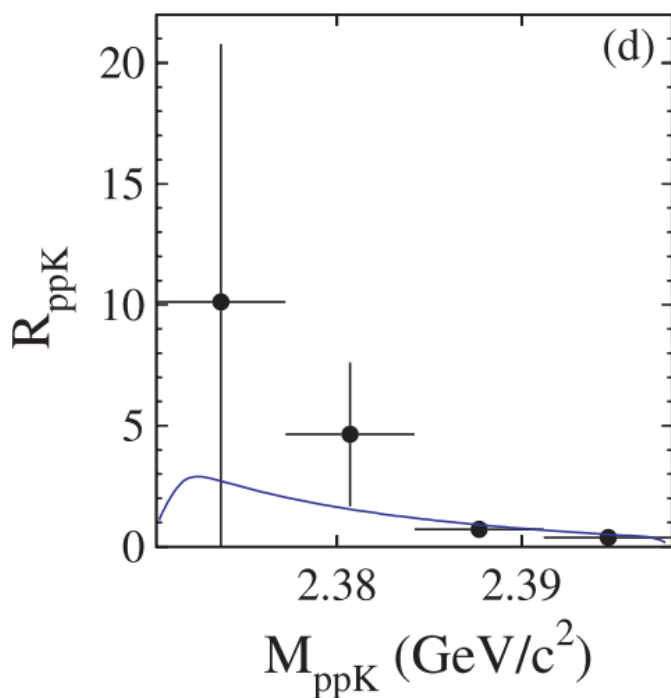
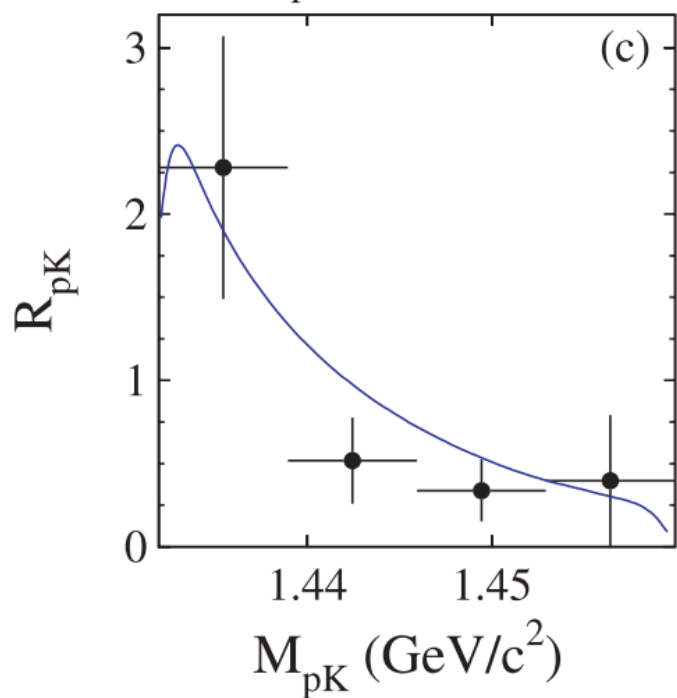

$$R_{ppK} = \frac{d\sigma/dM_{ppK^-}}{d\sigma/dM_{ppK^+}}$$

COSY-11
(Q = 28 MeV)

Parametrization of the Final State Interaction

- ❖ FSI indication in both total and differential cross sections at K^+K^- threshold

$$\left| M_{pp \rightarrow ppK^+K^-} \right|^2 \approx \left| M_0 \right|^2 \left| F_{FSI} \right|^2$$

$$F_{FSI} = F_{pp}(q) \times F_{p_1K^-}(k_1) \times F_{p_2K^-}(k_2)$$

$$F_{pp}(q) = \frac{e^{i\delta_{pp}(^1S_0)} \times \sin \delta_{pp}(^1S_0)}{C \times q}$$

$$F_{pK^-}(k) = \frac{1}{1 - ika}$$

$$a = (0 + i1.5) [\text{fm}]$$

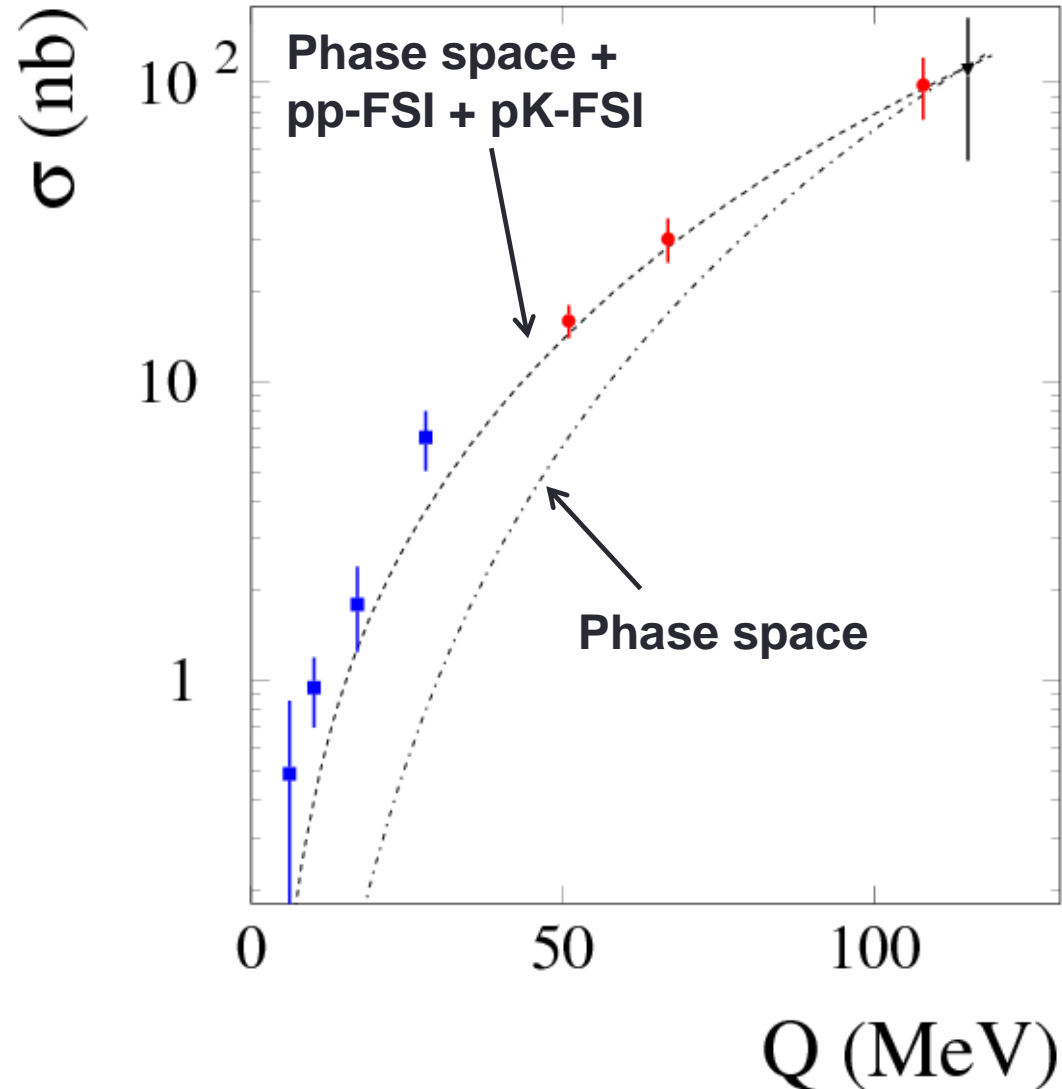

K⁺K⁻-FSI: coupled channel effects

$$\mathcal{F} = \left| \frac{B_1/(B_1 + B_0)}{\left(1 - i\frac{1}{2}q[A_1 - A_0]\right)(1 - ikA_1)} + \frac{B_0/(B_1 + B_0)}{\left(1 - i\frac{1}{2}q[A_0 - A_1]\right)(1 - ikA_0)} \right|$$

ANKE: A. Dzyuba et al., Phys. Lett. B668, 315 (2008)

$A_0 = (-0.45 + i1.63)$ fm ; $A_1 = (0.1 + i0.7)$ fm
(M. Ablikim et al., Phys. Lett. B 607 (2005) 243;)

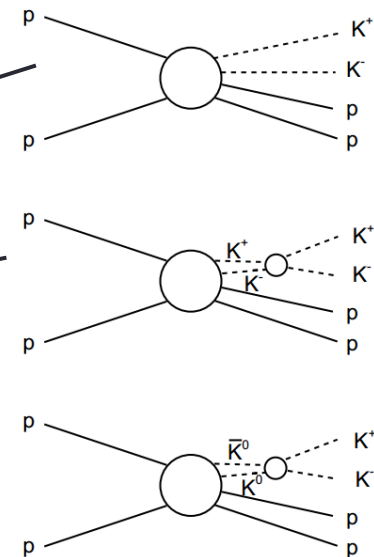

- ❖ With the ANKE statistics the expected cusp effects are not distinguishable from the elastic scattering of K⁺ and K⁻
- ❖ Isospin I= 0 state is favourable
- ❖ No indication of the $f_0(980)/a_0(980)$ influence
- ❖ More statistics at lower excess energy needed

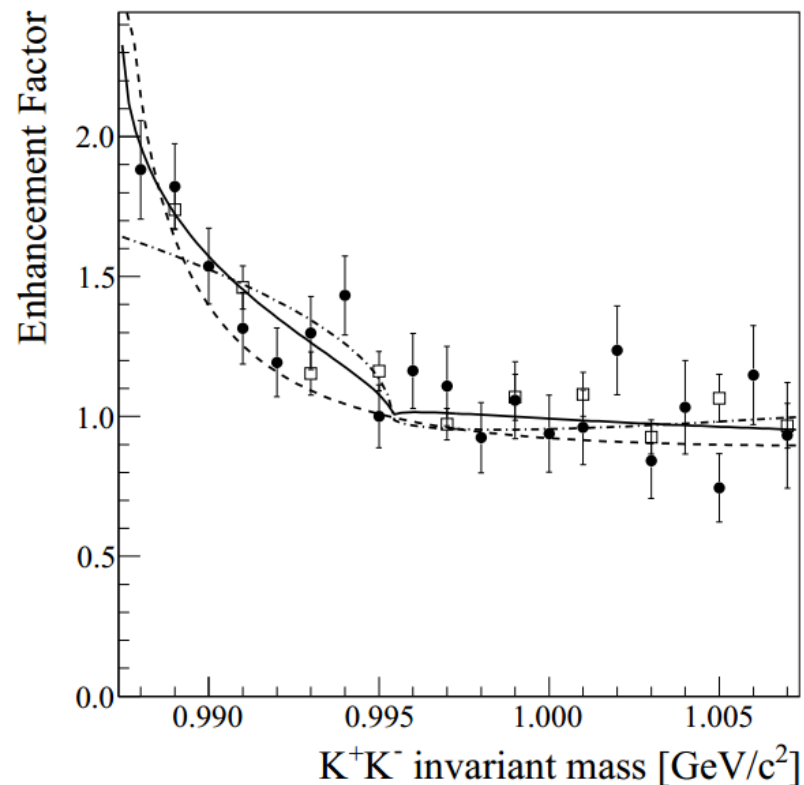

Analysis of the K^+K^- -FSI at COSY-11

$$\left| M_{pp \rightarrow ppK^+K^-} \right|^2 \approx \left| M_0 \right|^2 \left| F_{FSI} \right|^2$$

$$F_{FSI} = F_{pp}(q) \times F_{p_1K^-}(k_1) \\ \times F_{p_2K^-}(k_2) \times F_{K^+K^-}(k_3)$$

$$F_{pp}(q) = \frac{e^{i\delta_{pp}(^1S_0)} \times \sin \delta_{pp}(^1S_0)}{C \times q}$$

$$F_{pK^-}(k) = \frac{1}{1 - ika_{pK^-}}$$

$$F_{K^+K^-}(k_3) = \frac{1}{1 - ika_{K^+K^-}}$$

$$a_{pK^-} = (0 + i1.5) [\text{fm}]$$

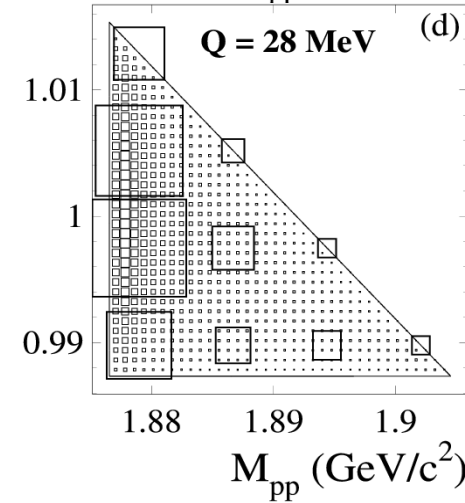
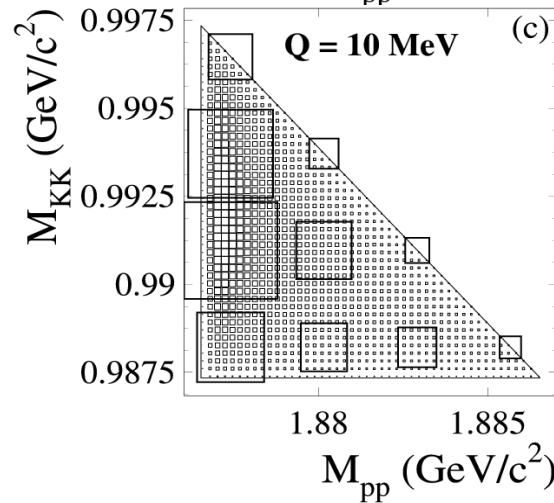
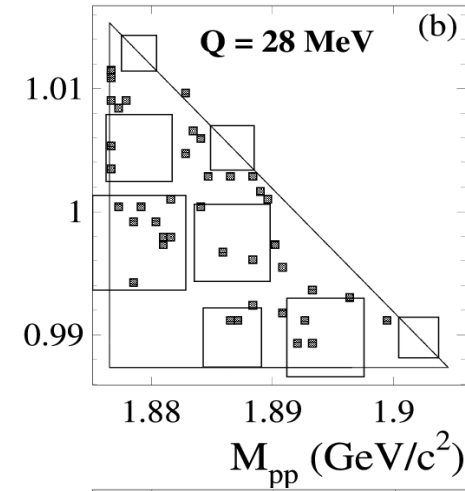
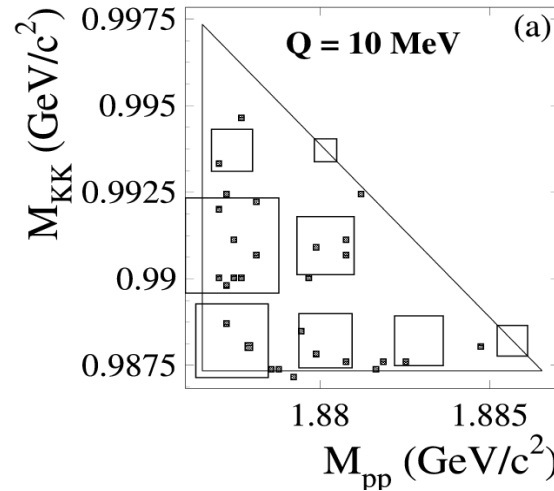

M. Silarski, et al., Phys. Rev. C 80, 045202 (2009)

$$a_{K^+K^-} = [(0.5_{-0.5}^{+4}) + i(3 \pm 3)] \text{ fm}$$

- ❖ Analysis of the Goldhaber plots measured at $Q = 10$ MeV (27 events) and $Q = 28$ MeV (30 events) + near threshold excitation function

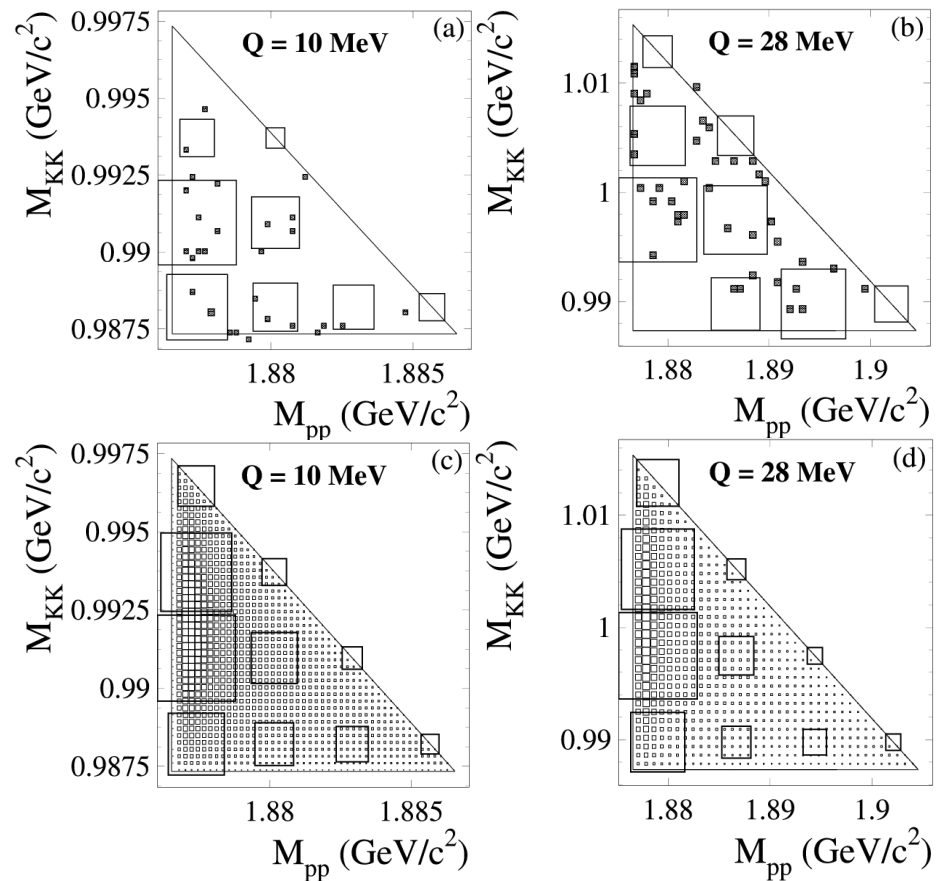
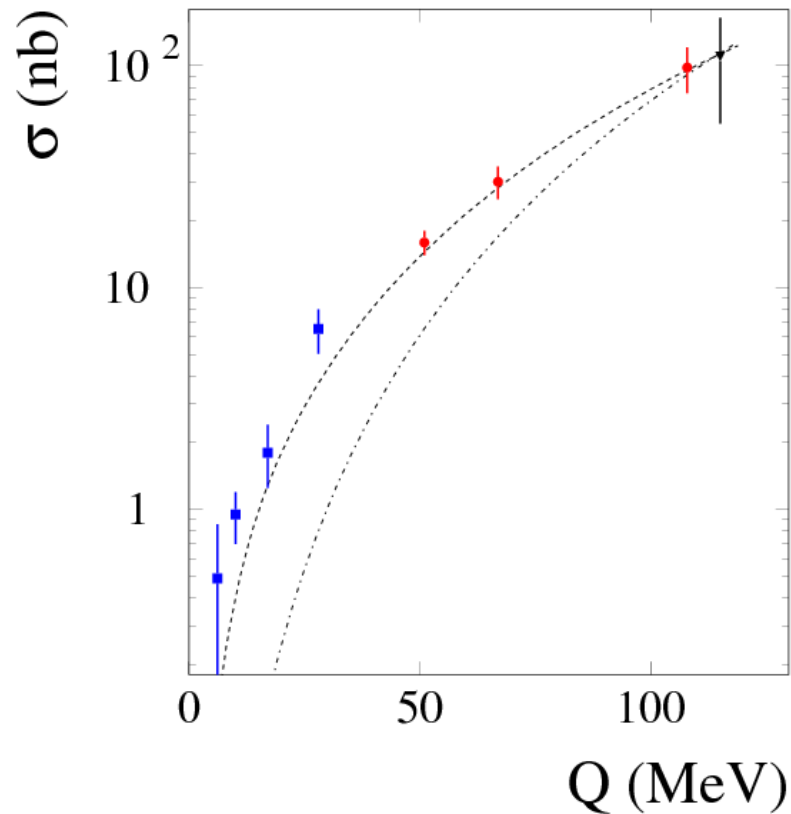

$$a_{pK^-} = (-0.65 + i0.78) [\text{fm}]$$

(Y. Yan, arXiv:0905.4818 [nucl-th])

$$F_{K^+K^-} = \frac{1}{\frac{1}{a_{K^+K^-}} + \frac{b_{K^+K^-} k_4^2}{2} - ik_4}$$

Results for the effective range expansion fit

$$\text{Re}(b_{K^+K^-}) = -0.1 \pm 0.4_{\text{stat}} \pm 0.3_{\text{sys}} \text{ fm}$$

$$\text{Im}(b_{K^+K^-}) = 1.2^{+0.1_{\text{stat}}+0.2_{\text{sys}}}_{-0.2_{\text{stat}}-0.0_{\text{sys}}} \text{ fm}$$

$$|\text{Re}(a_{K^+K^-})| = 8.0^{+6.0_{\text{stat}}}_{-4.0_{\text{stat}}} \text{ fm}$$

$$\text{Im}(a_{K^+K^-}) = 0.0^{+20.0_{\text{stat}}}_{-5.0_{\text{stat}}} \text{ fm}$$

M. Silarski, P. Moskal,
Phys. Rev. C 88, 025205 (2013)

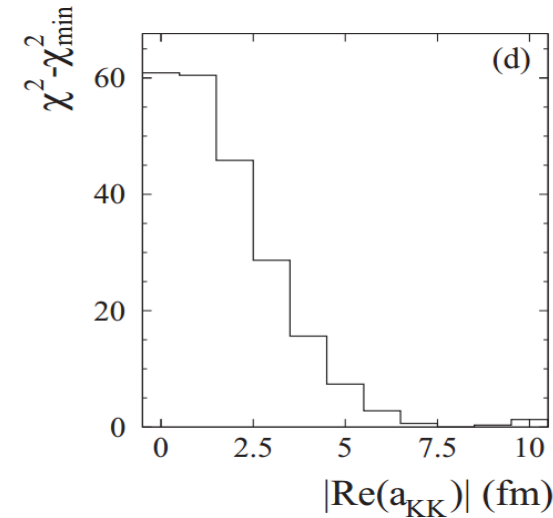
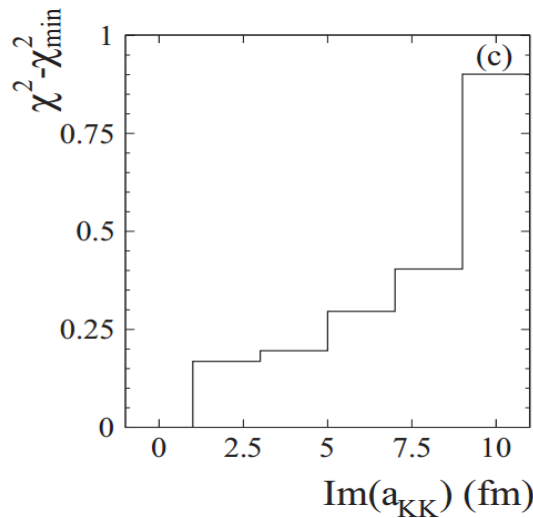
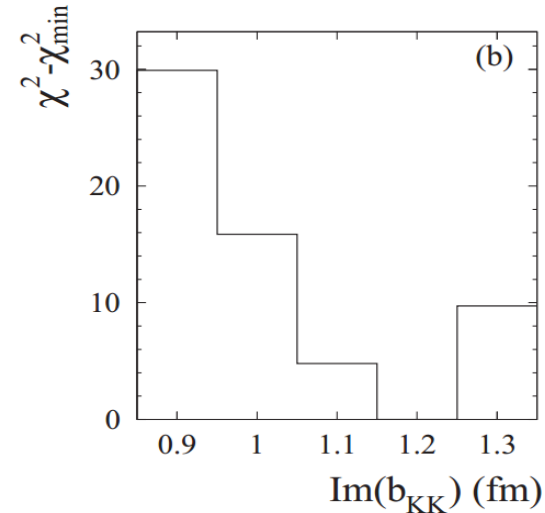
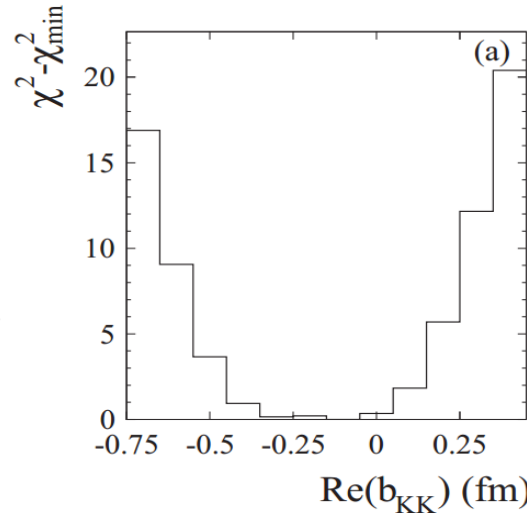

$$\chi^2(a_{K^+K^-}, \alpha) = \sum_{i=1}^8 \frac{(\sigma_i^{\text{exp}} - \alpha \sigma_i^m)^2}{(\Delta \sigma_i^{\text{exp}})^2} + 2 \cdot \sum_{i=1}^2 \sum_{k=1}^{10} [\beta_j N_{jk}^s - N_{jk}^e + N_{jk}^e \ln(\frac{N_{jk}^e}{\beta_j N_{jk}^s})]$$

Open questions

- ❖ Differential distributions at $Q=23.9$ MeV cannot be described by pK^- -FSI with $a_{pK^-} = i1.5$ fm.
- ❖ Possible influence of the $pp \rightarrow pK^+\Lambda(1405)$ reaction?
- ❖ Too simplified FSI model?

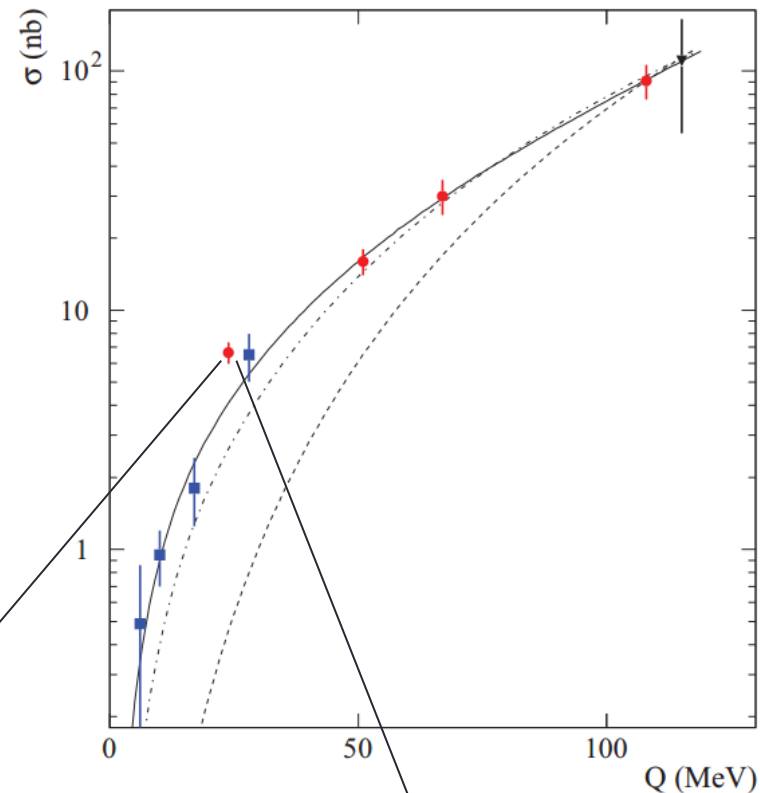

Q. J. Ye et al., Phys. Rev. C 87, 065203 (2013)

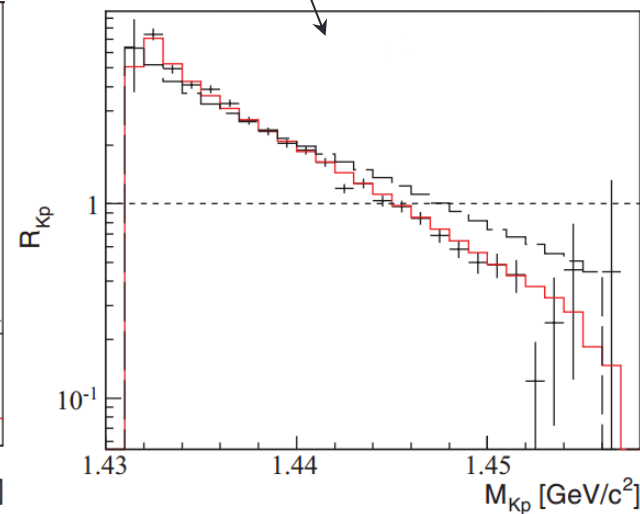
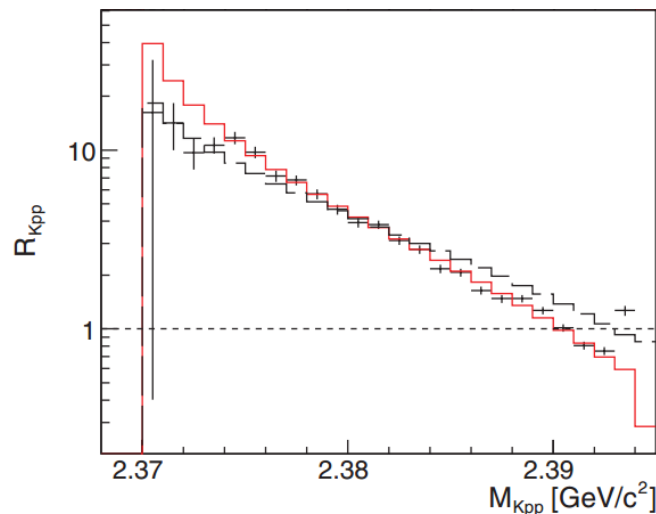

Conclusions & outlook

- ❑ The excitation function for the $pp \rightarrow ppK^+K^-$ reaction reveal an enhancement which may be assigned to the influence of the pK^- and K^+K^- interaction
- ❑ The ANKE factorization ansatz underestimates experimental data very close to threshold
- ❑ The coupled channel effects and production of $f_0(980)/a_0(980)$ are up to now not distinguishable even with high statistic measurements
- ❑ We have estimated the K^+K^- scattering length and effective range based on the near threshold data independently from a_{pK^-} obtained by the ANKE group
- ❑ The last ANKE measurement reveals that we still do not understand fully the dynamics of the near threshold $pp \rightarrow ppK^+K^-$

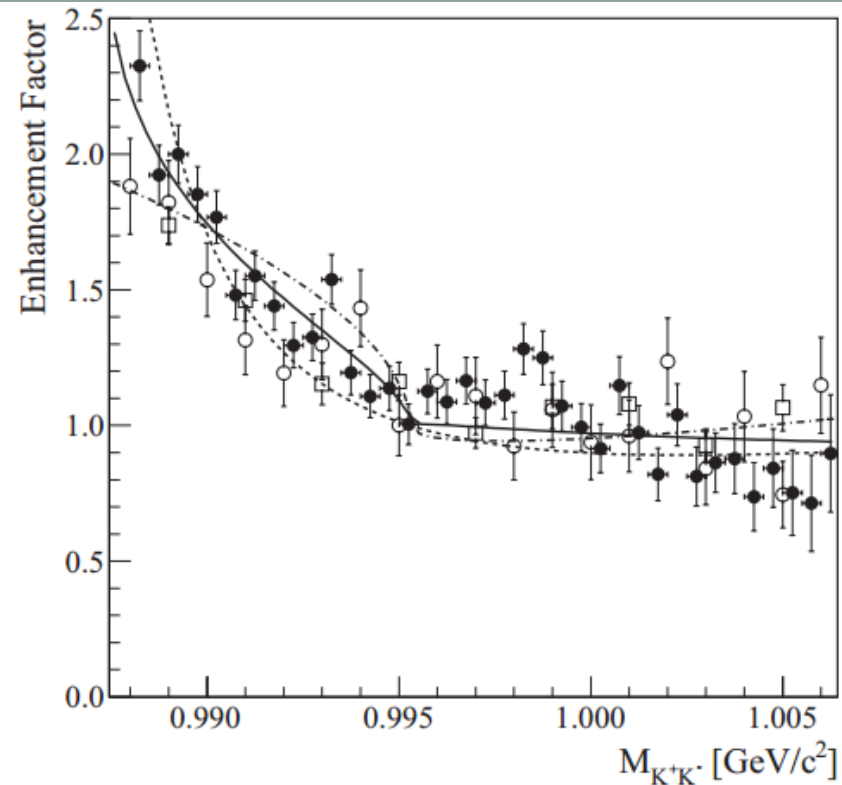

SPARES

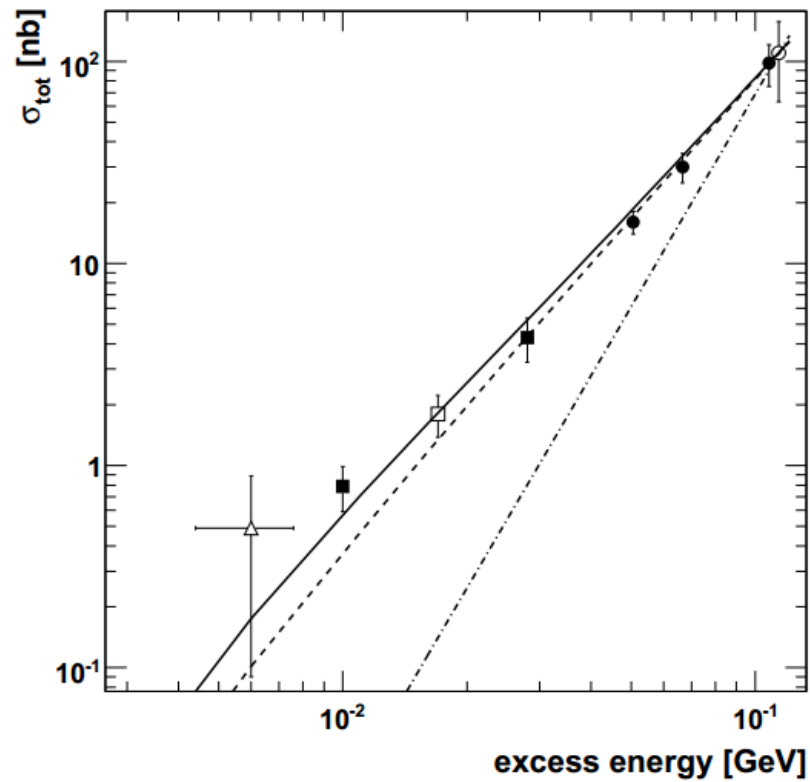

$$\sigma^m = \int \frac{\pi^2 |M|^2}{8s\sqrt{-B}} dM_{pp}^2 dM_{K^+K^-}^2 dM_{pK^-}^2 dM_{ppK^-}^2 dM_{ppK^+}^2$$

$$\beta_j = \frac{L_j \alpha \sigma_j^m}{N_j^{gen}}$$

$$F_{K^+K^-}(k_3) = \frac{1}{1 - ik_3 a_{K^+K^-}}$$

Generalization of the Dalitz Plot

- Probability of reaction yielding a state with the i -th particle in momentum range dp_i (in CM):

$$d^{12}R = d^3 p_1 d^3 p_2 d^3 p_3 d^3 p_4 \frac{1}{16E_1 E_2 E_3 E_4} \delta^3 \left(\sum_j \vec{p}_j \right) \delta \left(\sum_j E_j - \sqrt{s} \right) f^2$$

- Assuming that f depends only on invariant masses of the particles one obtains (Nyborg et al. Phys. Rev. 140 922 (1965)):

$$d^5 R = f^2 \frac{\pi^2}{8s\sqrt{-B}} dM_{12}^2 dM_{14}^2 dM_{34}^2 dM_{124}^2 dM_{134}^2$$



$$\left| M_{pp \rightarrow ppK^+K^-} \right|^2 \approx |M_0|^2 |F_{FSI}|^2$$

$$F_{FSI} = F_{pp}(q) \times F_{p_1K^-}(k_1) \times F_{p_2K^-}(k_2)$$

$$F_{pp}(q) = \frac{e^{-i\delta_{pp}(^1S_0)} \times \sin \delta_{pp}(^1S_0)}{C \times q}$$

$$F_{pK^-}(k) = \frac{1}{1 - ika}$$

$$a = (0 + i1.5)[\text{fm}]$$

